

US008568011B2

(12) **United States Patent**
Rillie et al.

(10) **Patent No.:** **US 8,568,011 B2**
(45) **Date of Patent:** **Oct. 29, 2013**

(54) **DAYLIGHTING DEVICES WITH AUXILIARY LIGHTING SYSTEM AND LIGHT TURNING FEATURES**

(75) Inventors: **David Windsor Rillie**, San Marcos, CA (US); **Keith Robert Kopitzke**, Fallbrook, CA (US); **Ding Yao Shay**, Vista, CA (US); **Paul August Jaster**, Carlsbad, CA (US)

(73) Assignee: **Solatube International, Inc.**, Vista, CA (US)

(*) Notice: Subject to any disclaimer, the term of this patent is extended or adjusted under 35 U.S.C. 154(b) by 0 days.

(21) Appl. No.: **13/333,594**

(22) Filed: **Dec. 21, 2011**

(65) **Prior Publication Data**

US 2012/0230020 A1 Sep. 13, 2012

Related U.S. Application Data

(63) Continuation-in-part of application No. 12/545,016, filed on Aug. 20, 2009, now Pat. No. 8,083,363, and a continuation-in-part of application No. 12/636,650, filed on Dec. 11, 2009, now Pat. No. 8,098,433.

(51) **Int. Cl.**
F21S 8/04 (2006.01)
E04D 13/03 (2006.01)

(52) **U.S. Cl.**
USPC **362/576**; 362/147; 359/591

(58) **Field of Classification Search**
USPC 362/1, 2, 20, 228, 576, 147, 148, 150, 362/404, 555, 557, 558; 52/200; 359/591, 359/597

See application file for complete search history.

(56) **References Cited**

U.S. PATENT DOCUMENTS

668,404 A	2/1901	Hanneborg
2,828,734 A	11/1958	Boyd
3,307,303 A	3/1967	Bloxsom
4,018,211 A	4/1977	Barr
4,078,548 A	3/1978	Kapany
4,114,186 A	9/1978	Dominguez
4,126,379 A	11/1978	Wu

(Continued)

FOREIGN PATENT DOCUMENTS

BE	1 014 530	12/2003
CA	2337293	8/2002

(Continued)

OTHER PUBLICATIONS

“LED Light add on Kit for skylight tubes,” Wild Ideas Light Company Ltd., published at least as early as Apr. 2009.

(Continued)

Primary Examiner — Thomas Sember

(74) *Attorney, Agent, or Firm* — Knobbe, Martens, Olson & Bear, LLP

(57) **ABSTRACT**

Some embodiments provide a daylighting apparatus comprising an internally reflective tube configured to direct daylight from a first end of the tube to a second end of the tube opposite the first end. A diffuser can be positioned at the second end of the tube. The diffuser can comprise a first optical structure configured such that, when the daylighting apparatus is installed with the first end positioned outside a room and the second end positioned to provide light to the room, a reflected portion of the daylight is directed towards at least one upper region (e.g., a ceiling or upper wall surface) of the room and a transmitted portion of the daylight is directed towards at least one lower region (e.g., a floor surface) of the room.

19 Claims, 11 Drawing Sheets

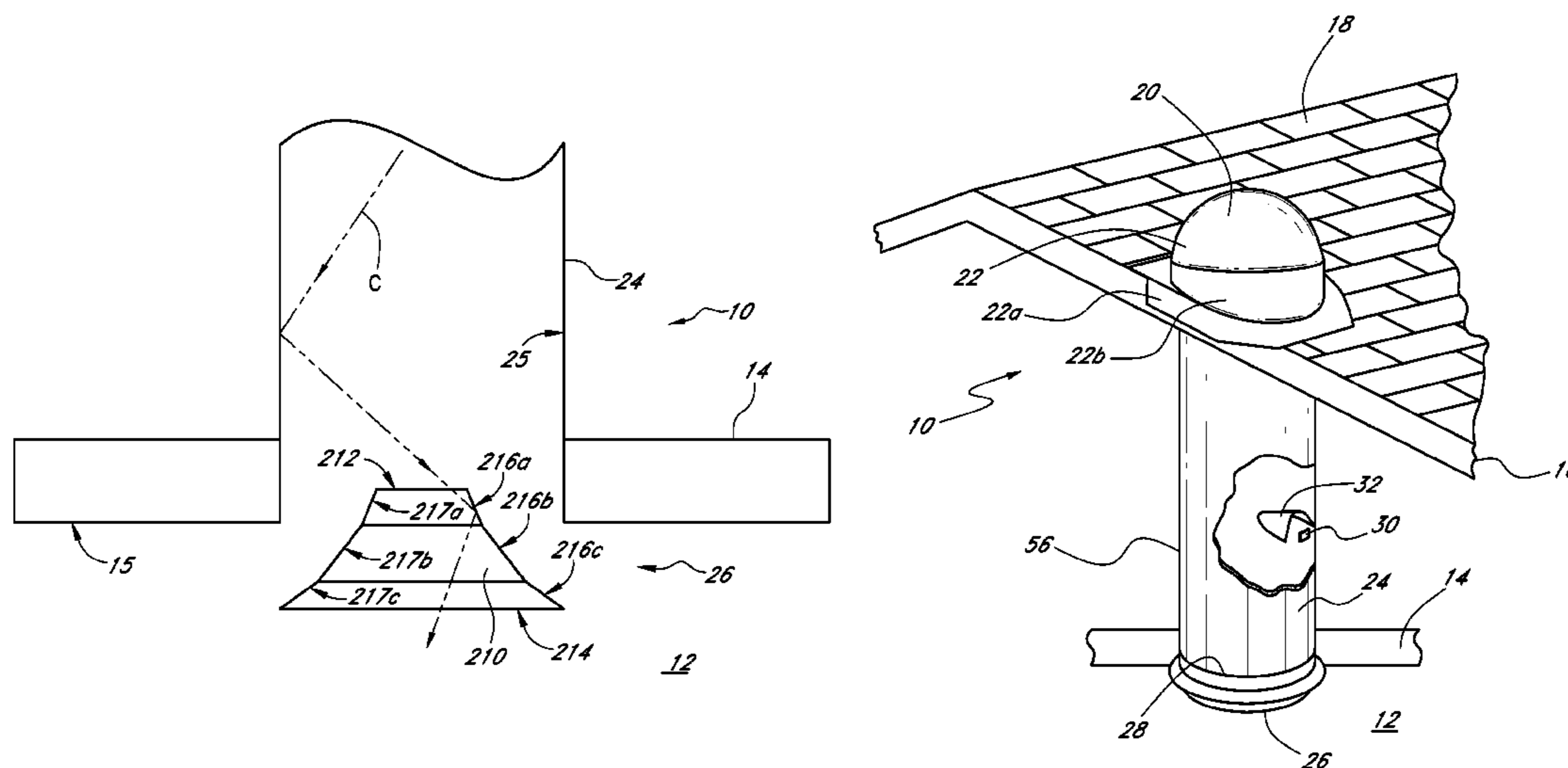

(56)

References Cited

U.S. PATENT DOCUMENTS

4,334,524	A	6/1982	McCullough et al.	7,546,168	B2	6/2009	Walters et al.
4,429,952	A	2/1984	Dominguez	7,546,709	B2	6/2009	Jaster et al.
4,539,625	A	9/1985	Bornstein et al.	7,576,647	B1	8/2009	Mudge
4,557,565	A	12/1985	Ruck et al.	7,585,088	B2	9/2009	Tyson
4,615,579	A	10/1986	Whitehead	7,586,408	B1	9/2009	Mudge
4,733,505	A	3/1988	Van Dame	7,603,184	B2	10/2009	Walters et al.
5,099,622	A	3/1992	Sutton	7,614,767	B2	11/2009	Zulim et al.
5,117,811	A	6/1992	Taylor	7,621,656	B2	11/2009	Tyson
5,228,772	A	7/1993	Mitchell et al.	7,622,701	B2	11/2009	Stevens et al.
5,360,659	A	11/1994	Arends et al.	7,639,423	B2	12/2009	Kinney et al.
5,467,564	A	11/1995	DeKeyser et al.	7,642,501	B1	1/2010	Fassbender et al.
5,493,824	A	2/1996	Webster et al.	7,670,021	B2	3/2010	Chou
5,517,358	A	5/1996	Dominguez	7,690,816	B2	4/2010	Tyson et al.
5,528,471	A	6/1996	Green	7,736,014	B2	6/2010	Blomberg
5,546,712	A	8/1996	Bixby	7,737,640	B2	6/2010	Marques et al.
5,596,848	A	1/1997	Lynch	7,757,444	B1	7/2010	Halliday
5,648,873	A	7/1997	Jaster et al.	7,761,260	B2	7/2010	Walters et al.
5,655,339	A	8/1997	DeBlock et al.	7,771,095	B2	8/2010	Dorogi
5,662,403	A	9/1997	Akashi et al.	7,784,971	B2	8/2010	Dorogi
5,729,387	A	3/1998	Takahashi et al.	7,806,550	B2	10/2010	Tyson et al.
5,735,262	A	4/1998	Houtman	7,813,041	B2	10/2010	Briee et al.
5,830,548	A	11/1998	Andersen et al.	7,817,063	B2	10/2010	Hawkins et al.
5,878,539	A	3/1999	Grubb	7,828,459	B2	11/2010	Rains
5,896,712	A	4/1999	Chao	7,839,295	B2	11/2010	Ries, II
5,896,713	A	4/1999	Chao et al.	7,845,825	B2	12/2010	Ramer et al.
5,897,201	A	4/1999	Simon	7,845,829	B2	12/2010	Shaner
5,999,323	A	12/1999	Wood	7,850,342	B2	12/2010	Abdelsamed
6,000,170	A	12/1999	Davis	7,863,832	B2	1/2011	Lane et al.
RE36,496	E	1/2000	Sutton	7,866,855	B2	1/2011	Abdelsamed
6,035,593	A	3/2000	Chao et al.	7,883,237	B2	2/2011	Zhang et al.
6,104,854	A	8/2000	Masaki et al.	7,883,239	B2	2/2011	Rains, Jr. et al.
6,130,781	A	10/2000	Gauvin	7,886,492	B2	2/2011	Kelly et al.
6,142,645	A	11/2000	Han	7,896,521	B2	3/2011	Becker et al.
6,178,707	B1	1/2001	Bengtson	7,911,359	B2	3/2011	Walters et al.
6,219,977	B1	4/2001	Chao et al.	7,918,589	B2	4/2011	Mayfield, III et al.
6,239,910	B1	5/2001	Digert	7,939,793	B2	5/2011	Rains, Jr. et al.
6,256,947	B1	7/2001	Grubb	7,939,794	B2	5/2011	Rains, Jr. et al.
6,321,493	B1	11/2001	Rillie et al.	7,950,817	B2	5/2011	Zulim et al.
6,363,667	B2	4/2002	O'Neill	7,982,956	B2	7/2011	Kinney et al.
6,363,668	B2	4/2002	Rillie et al.	8,018,653	B2	9/2011	Jaster
6,391,400	B1	5/2002	Russell et al.	8,082,705	B2	12/2011	Jaster et al.
6,412,238	B2	7/2002	Rillie et al.	8,083,363	B2	12/2011	Jaster
6,415,563	B2	7/2002	Rillie	8,098,433	B2	1/2012	Rillie et al.
6,438,803	B2	8/2002	Rillie et al.	8,132,375	B2	3/2012	Jaster
6,456,437	B1	9/2002	Lea et al.	8,300,323	B2	10/2012	Hoch et al.
6,493,145	B1	12/2002	Aoki et al.	8,371,078	B2	2/2013	Jaster
6,502,950	B2	1/2003	Signer	2001/0049916	A1	12/2001	Rillie et al.
RE38,217	E	8/2003	De Block et al.	2002/0060283	A1	5/2002	Jordan et al.
6,604,329	B2	8/2003	Hoy et al.	2002/0073635	A1	6/2002	Erskine
6,623,137	B1	9/2003	Marsonette	2004/0050380	A1	3/2004	Abe
6,655,814	B1	12/2003	Tagawa et al.	2005/0039789	A1	2/2005	Kim
6,699,558	B1	3/2004	Milburn	2005/0078483	A1	4/2005	Bernard et al.
6,827,445	B2	12/2004	Abe et al.	2005/0128728	A1	6/2005	Eisenman et al.
6,840,645	B2	1/2005	Eisenman et al.	2005/0166490	A1	8/2005	Darmer et al.
6,870,673	B2	3/2005	Cromer et al.	2005/0188629	A1	9/2005	Rillie et al.
7,040,061	B2	5/2006	Rillie et al.	2005/0243430	A1	11/2005	Cuttle
7,057,821	B2	6/2006	Zincone	2005/0252111	A1	11/2005	Prenn et al.
7,082,726	B2	8/2006	Prenn et al.	2006/0288645	A1	12/2006	Konstantino et al.
7,134,254	B1	11/2006	Van Gelder	2007/0163732	A1	7/2007	Konstantin et al.
7,146,768	B2	12/2006	Rillie	2007/0271848	A1	11/2007	Wolf et al.
7,159,364	B2	1/2007	Rillie	2008/0035275	A1	2/2008	Konstantin
7,168,211	B2	1/2007	Prenn et al.	2008/0104903	A1	5/2008	Jaster
7,185,464	B2	3/2007	Bracale	2008/0250733	A1	10/2008	Konstantin
7,222,461	B2	5/2007	Piano et al.	2008/0304263	A1	12/2008	Paulussen
7,296,908	B1	11/2007	Pickard et al.	2009/0032102	A1	2/2009	Chen et al.
7,322,156	B1	1/2008	Rillie et al.	2009/0141487	A1	6/2009	Gould et al.
7,350,327	B1	4/2008	Logan et al.	2009/0322250	A1	12/2009	Zulim et al.
7,395,636	B2	7/2008	Blomberg	2010/0053971	A1	3/2010	Aggarwal et al.
7,438,440	B2	10/2008	Dorogi	2010/0091396	A1	4/2010	Hutson et al.
7,455,422	B2	11/2008	Gould et al.	2010/0110684	A1	5/2010	Abdelsamed et al.
7,481,552	B2	1/2009	Mayfield, III et al.	2010/0127625	A1	5/2010	Minarczyk et al.
7,501,768	B2	3/2009	Lane et al.	2010/0149804	A1	6/2010	Abdelsamed et al.
7,510,305	B2	3/2009	Straton et al.	2010/0232158	A1	9/2010	McCanless
7,529,594	B2	5/2009	Walters et al.	2010/0246193	A1	9/2010	Clifton et al.
7,546,167	B2	6/2009	Walters et al.	2010/0271610	A1	10/2010	Soer et al.
				2010/0274945	A1	10/2010	Westrick, Jr. et al.
				2010/0287081	A1	11/2010	Walters et al.
				2010/0309556	A1	12/2010	Jaster
				2010/0325979	A1	12/2010	Jaster

(56)

References Cited

U.S. PATENT DOCUMENTS

2011/0019410 A1 1/2011 Ibanez et al.
 2011/0032709 A1 2/2011 Tyson et al.
 2011/0051413 A1 3/2011 Hand
 2011/0067824 A1 3/2011 Konstantin et al.
 2011/0103042 A1 5/2011 Tirrell et al.
 2011/0110086 A1 5/2011 Barnwell et al.
 2011/0127557 A1 6/2011 Ramer et al.
 2011/0134649 A1 6/2011 Becker et al.
 2011/0242810 A1 10/2011 Lopez Querol et al.
 2011/0289869 A1 12/2011 Jaster et al.
 2012/0230020 A1 9/2012 Rillie et al.
 2013/0083554 A1 4/2013 Jaster

FOREIGN PATENT DOCUMENTS

CN 1399095 A 2/2003
 CN 201035179 Y 3/2008
 CN 201090939 Y 7/2008
 CN 101493205 A 7/2009
 DE 4012333 C1 6/1991
 DE 4140851 A1 6/1993
 EP 1 306 606 5/2003
 GB 933133 8/1963
 GB 2 384 022 7/2003
 GB 2 400 885 10/2007
 JP 60 166906 8/1985
 JP 60142413 9/1985

JP 60164704 11/1985
 JP 60166906 11/1985
 JP H08 7619 1/1996
 JP 2001 184913 7/2001
 JP 2003 157707 5/2003
 KR 10 0713802 5/2007
 KR 10-2009-0113435 11/2009
 KR 10 0970152 7/2010
 KR 10 2011 0032039 3/2011
 KR 10 2011 0062239 6/2011
 WO WO 2006/028703 3/2006
 WO WO 2010/070169 6/2010

OTHER PUBLICATIONS

“2301 Optical Lighting Film” Technical Specification, Effective Date: Feb. 1, 2000, 3M Specified Construction Products Department, <http://www.mmm.com/office>.
 “3M Daylighting Film DF2000MA”, Product Bulletin DF2000MA, Release A, Jun. 2006, 3M Graphics Market Center, St. Paul, MN.
 Ge et al., “Heat Loss Calculation of Compound Honeycomb Solar Collection”; Journal of Thermal Science, vol. 2, No. 4, pp. 254-259, Oct. 1993.
 Kaushika et al., “Solar Transparent Insulation Materials: A Review”; Renewable and Sustainable Energy Reviews, vol. 7, pp. 317-351, 2003.
 Sunflower Corporation, “Sustainable Commercial Daylighting Technical Overview”, undated, received on Dec. 11, 2009.
 International Search Report and Written Opinion mailed March 28, 2013, International Application No. PCT/US2012/058085 filed Sep. 28, 2012.

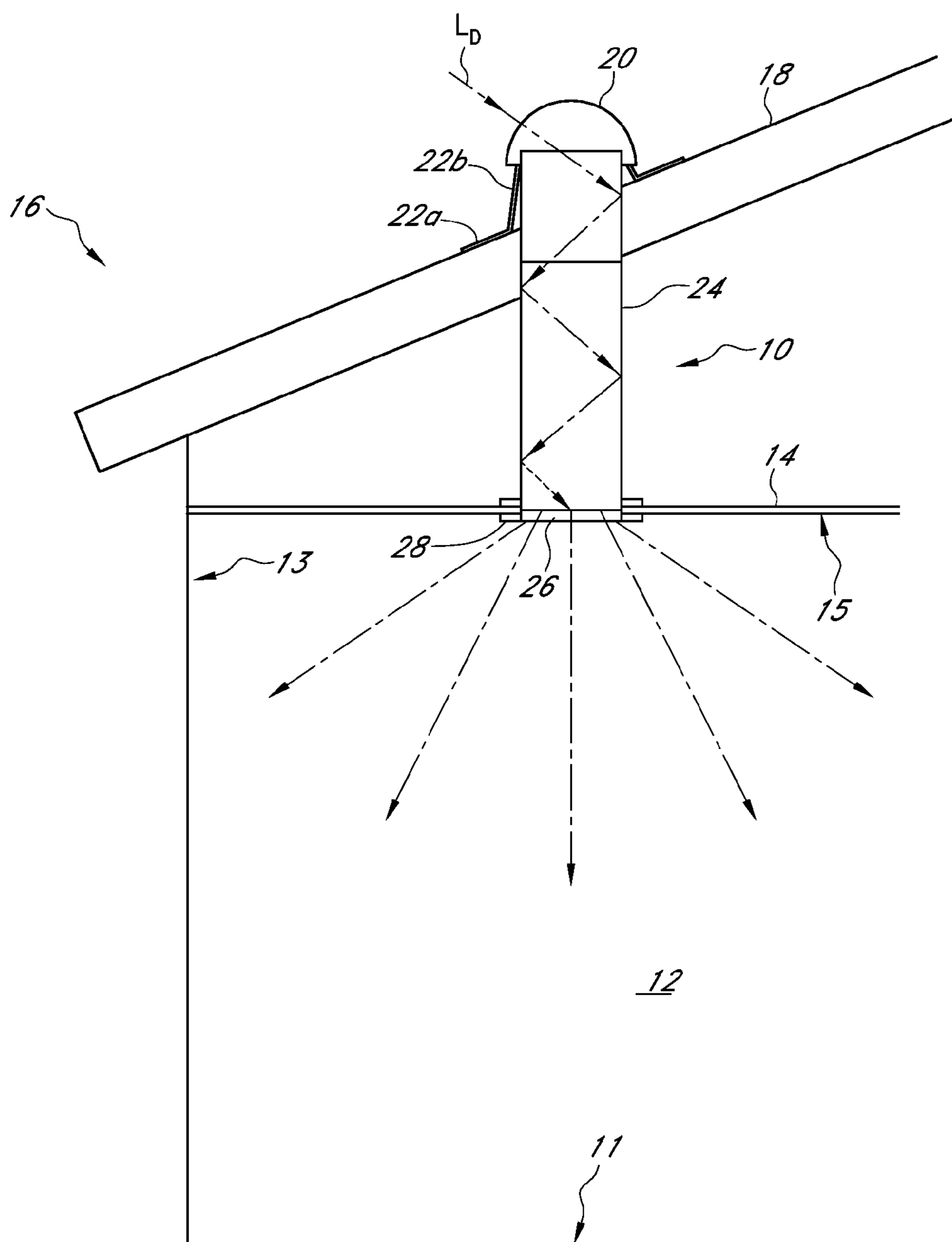

FIG. 1

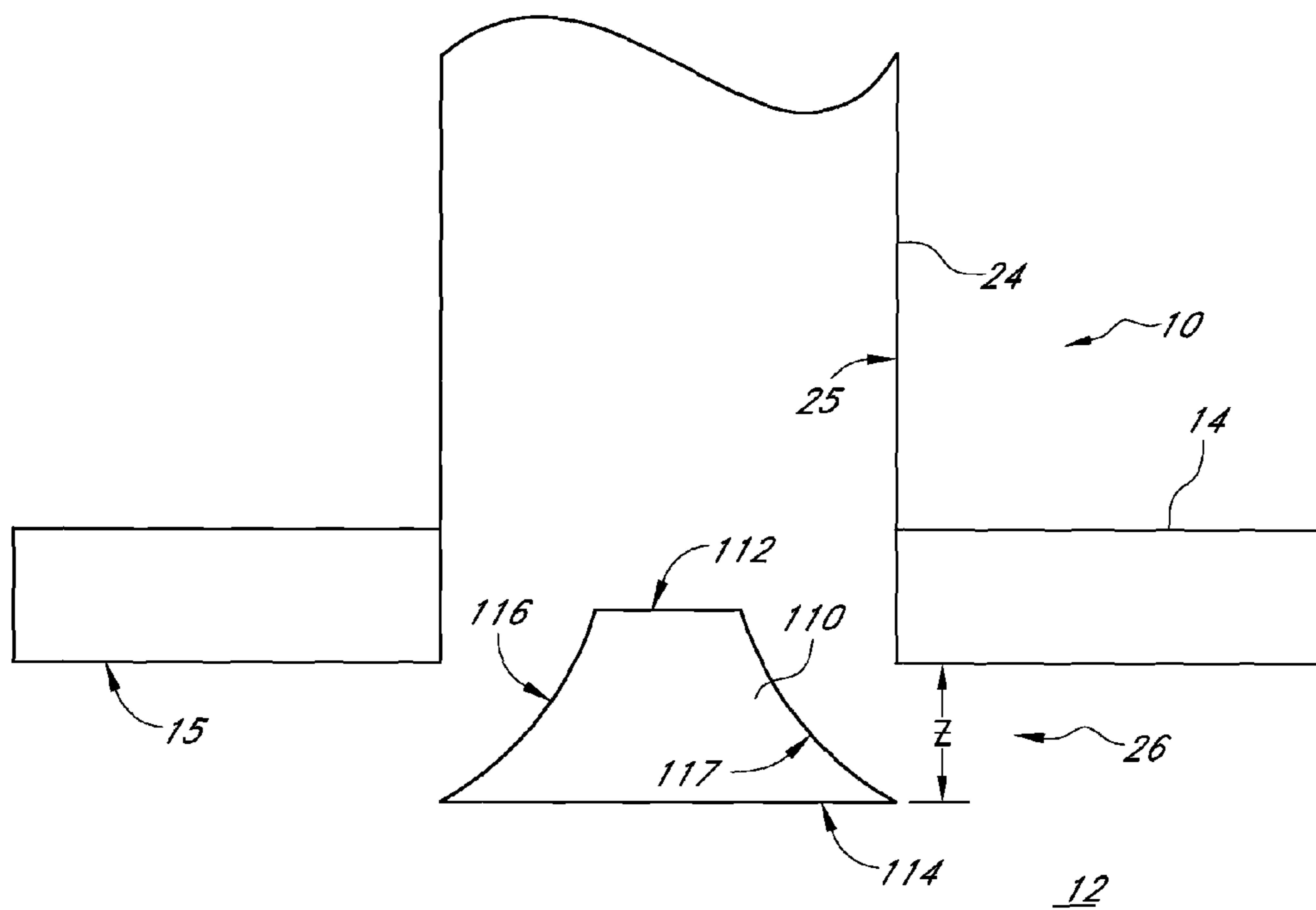

FIG. 2A

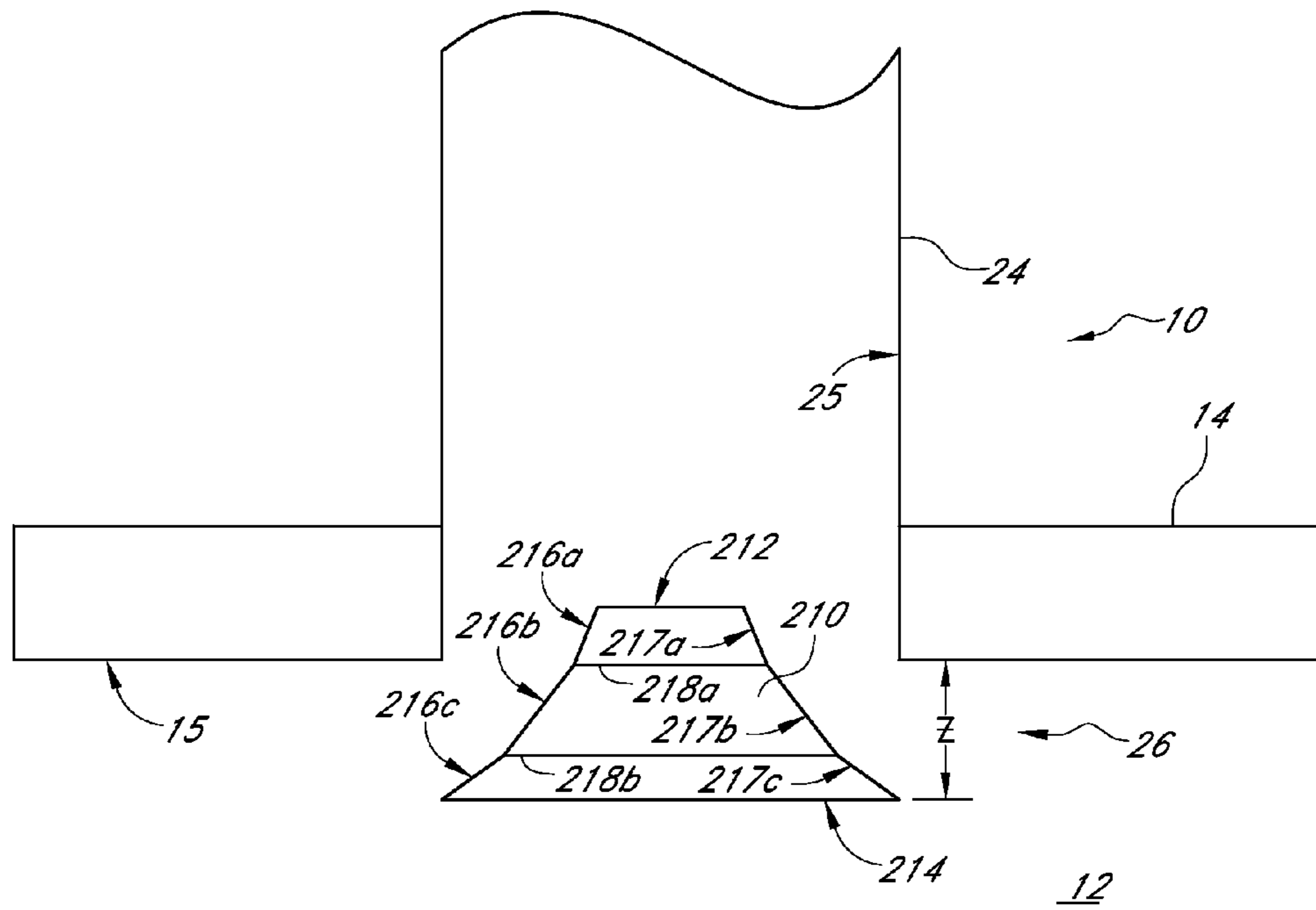

FIG. 2B

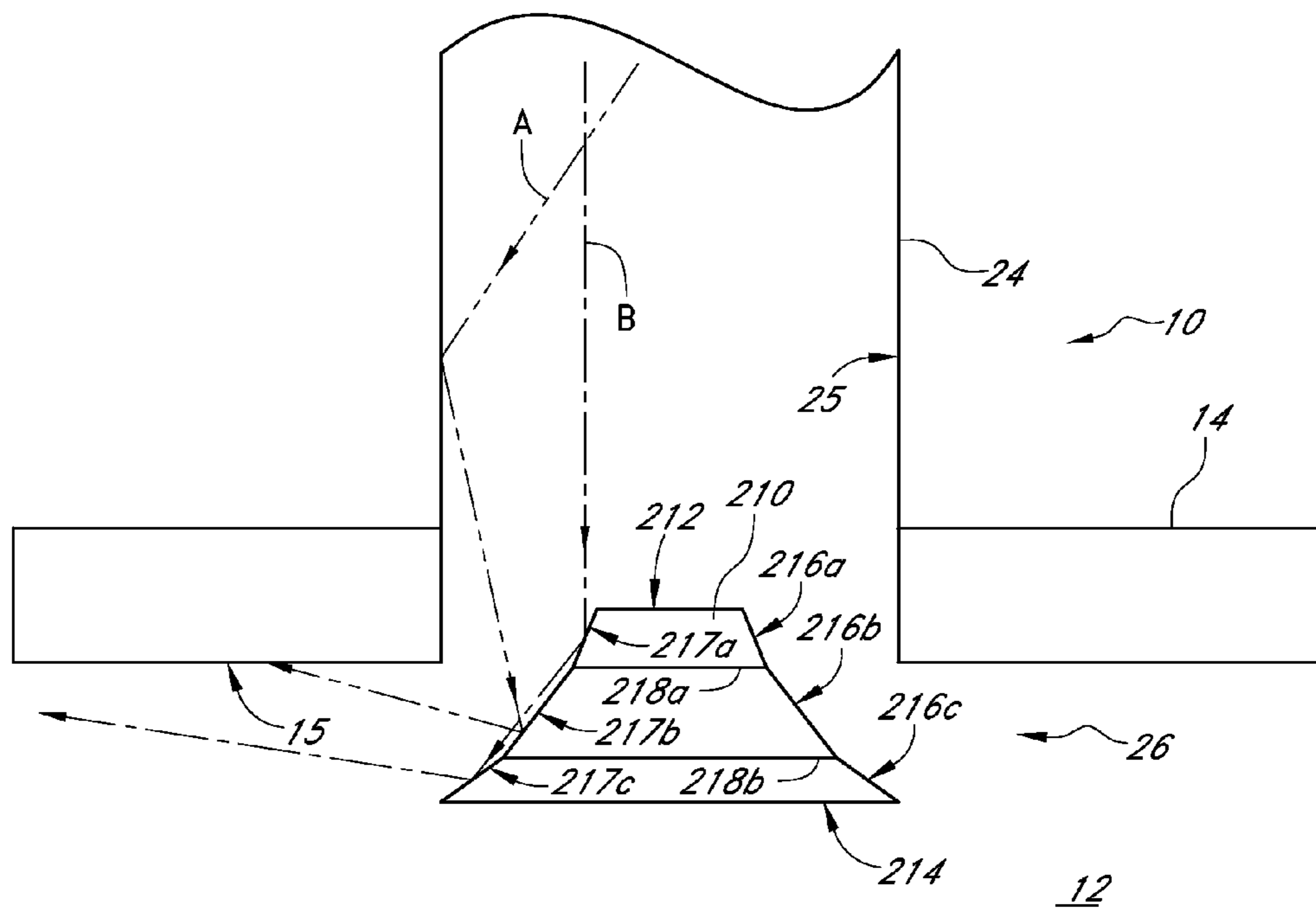

FIG. 3

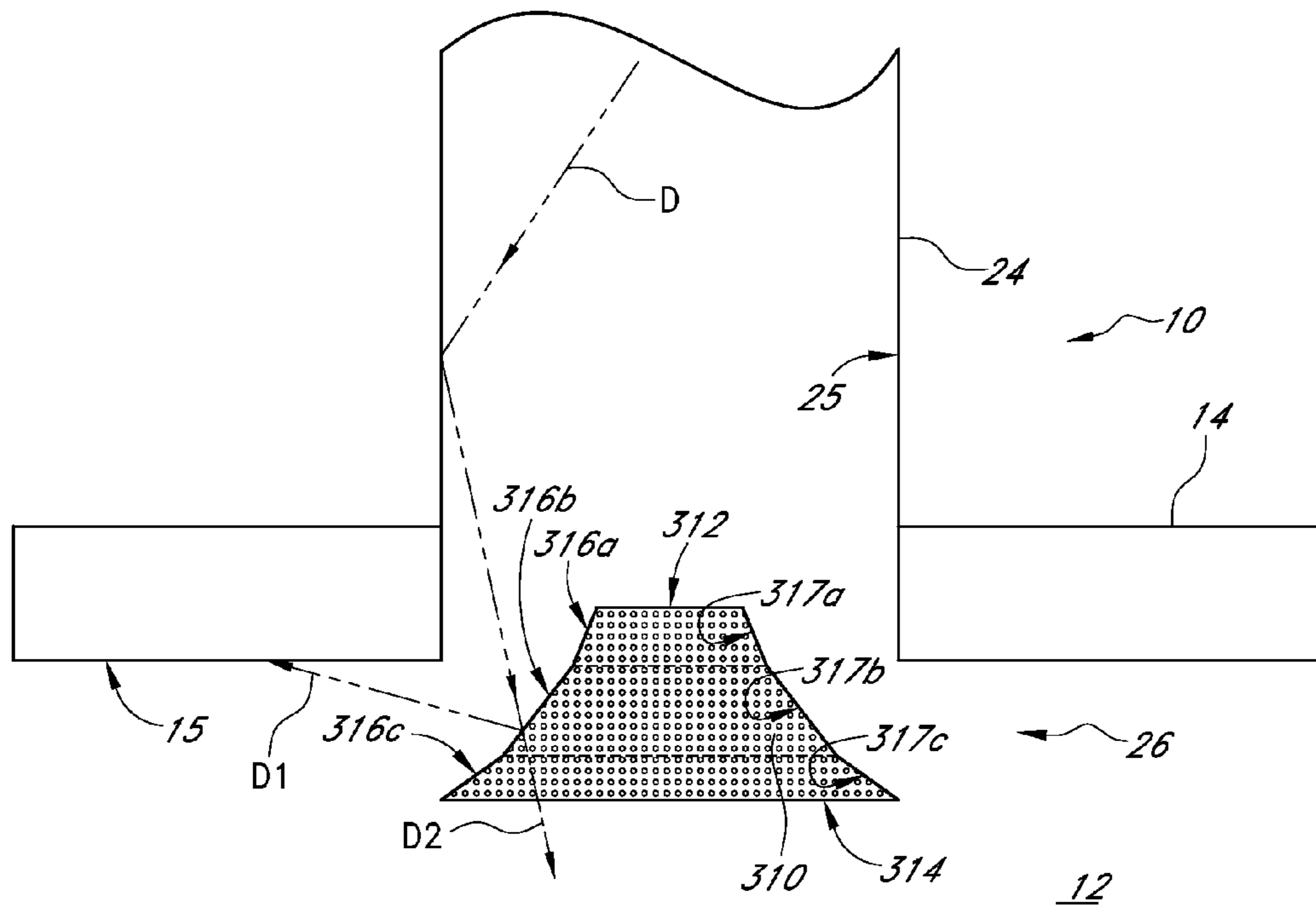

FIG. 5

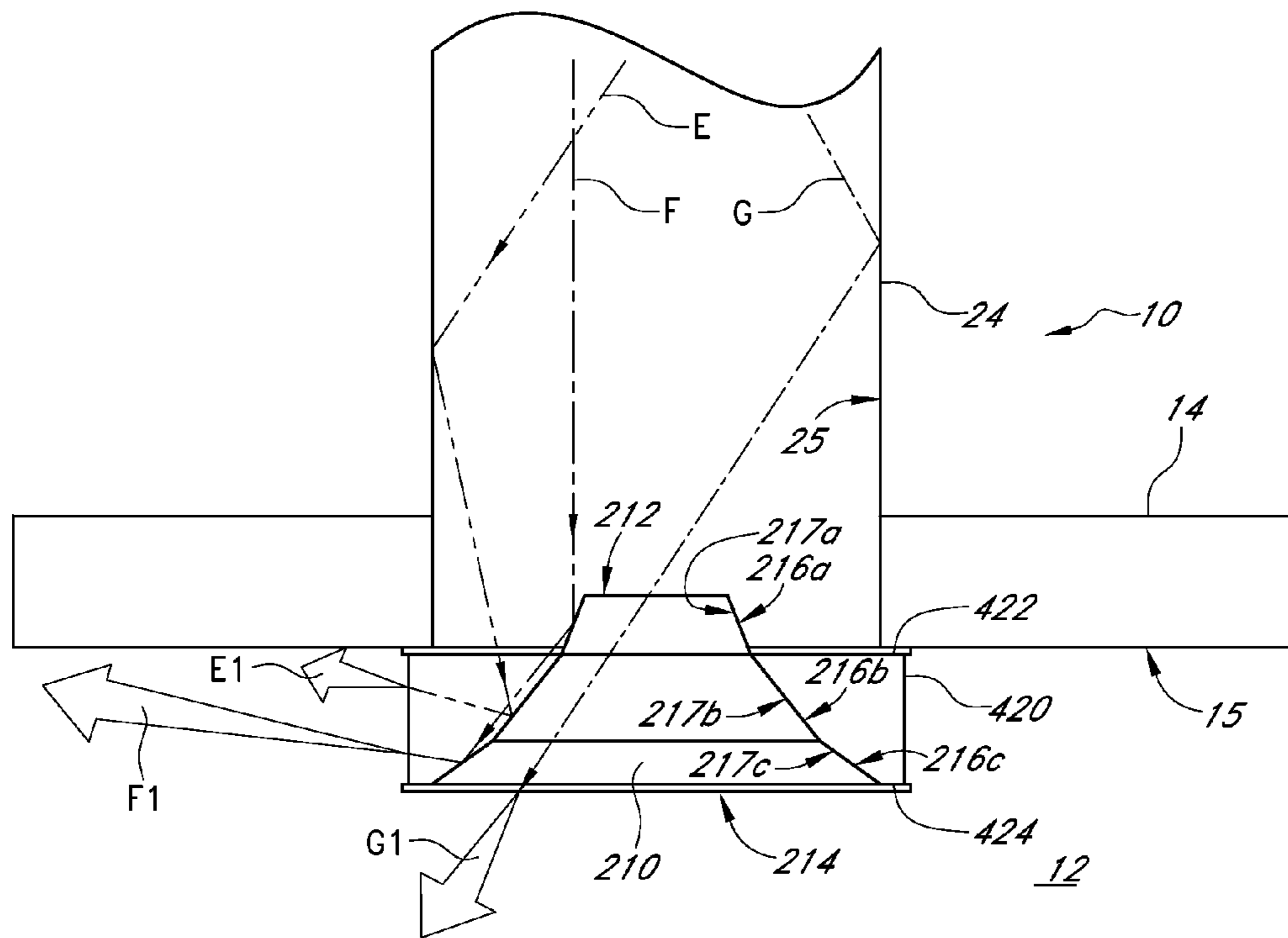

FIG. 6

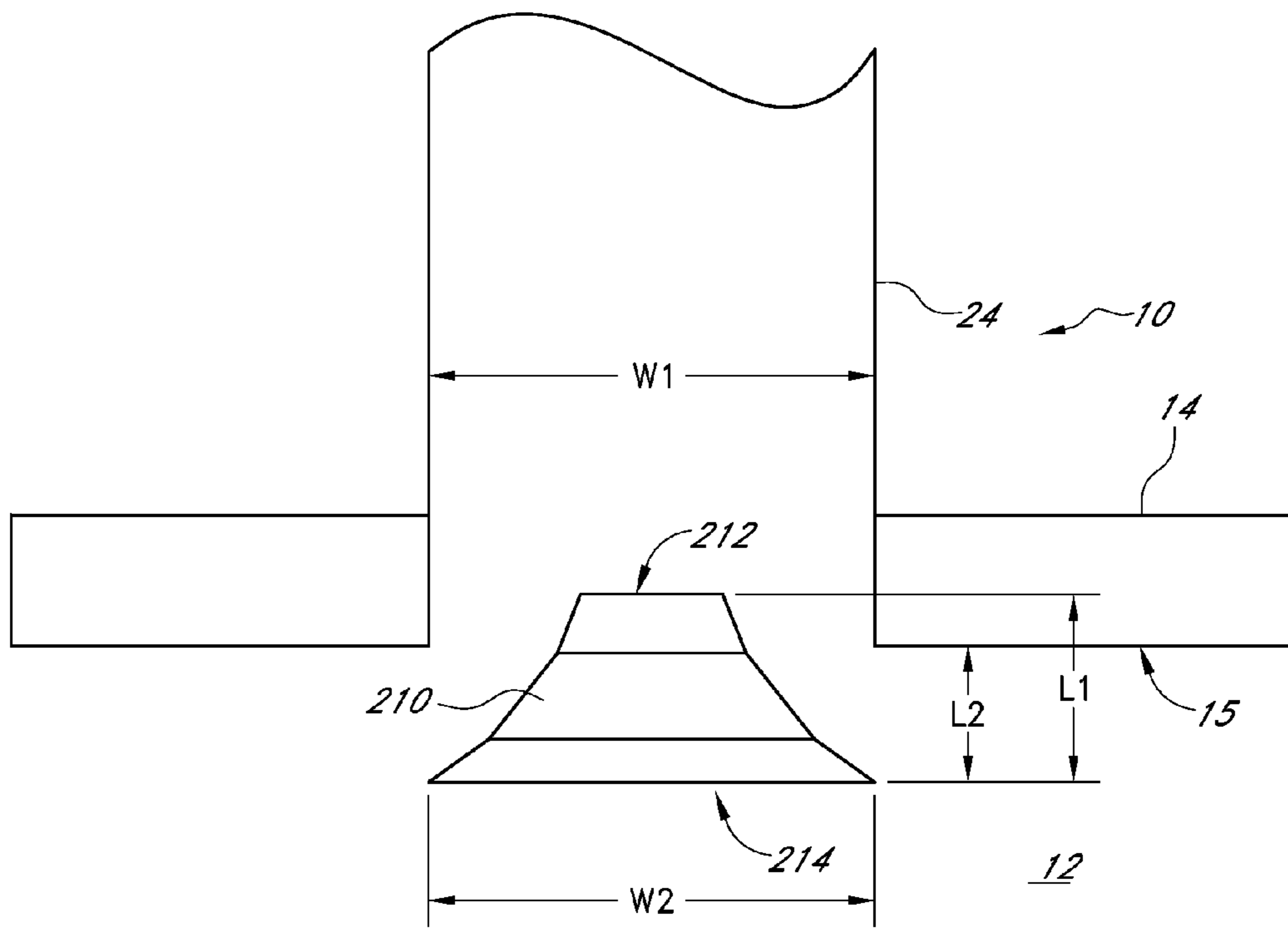
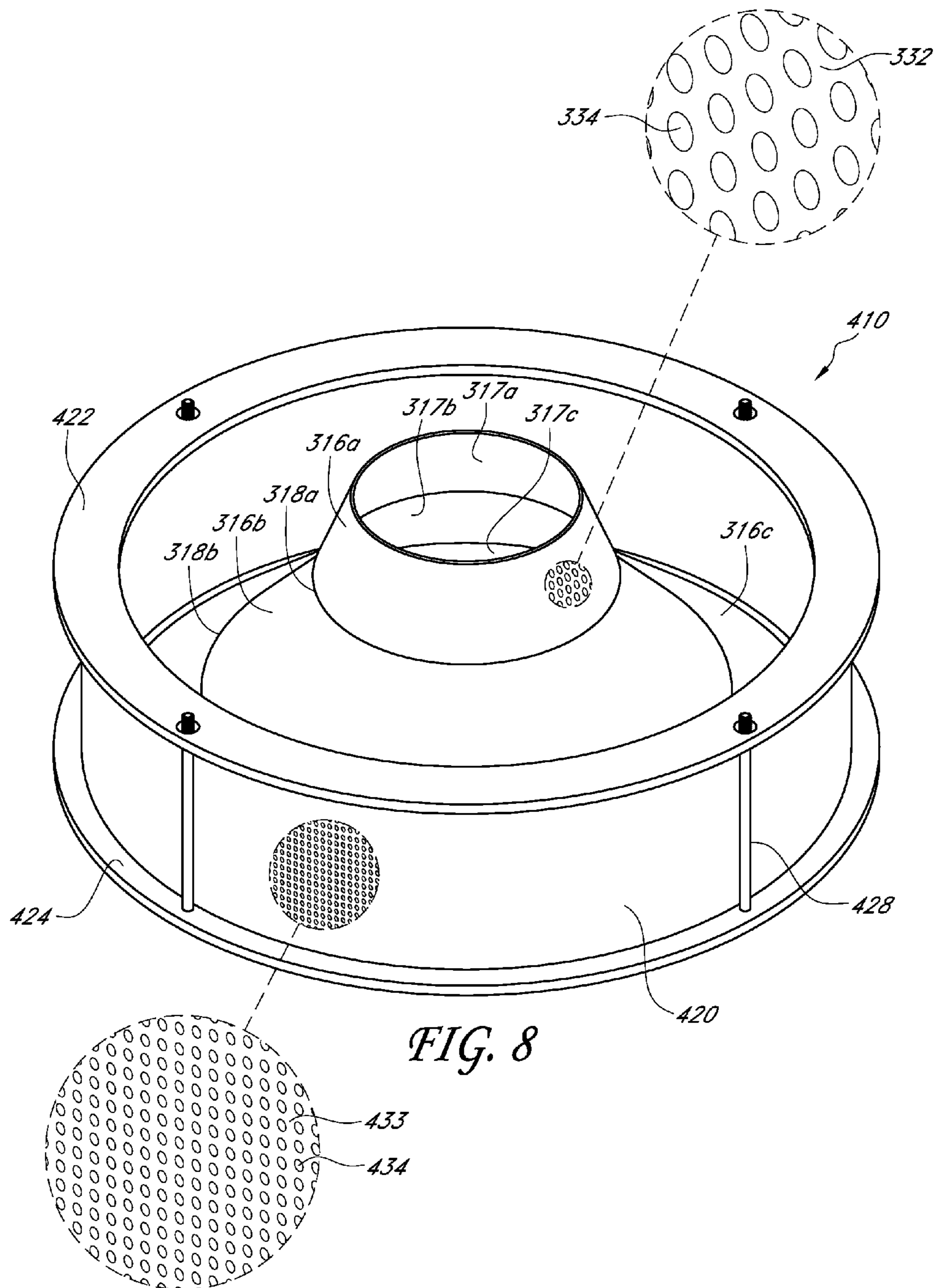

FIG. 7



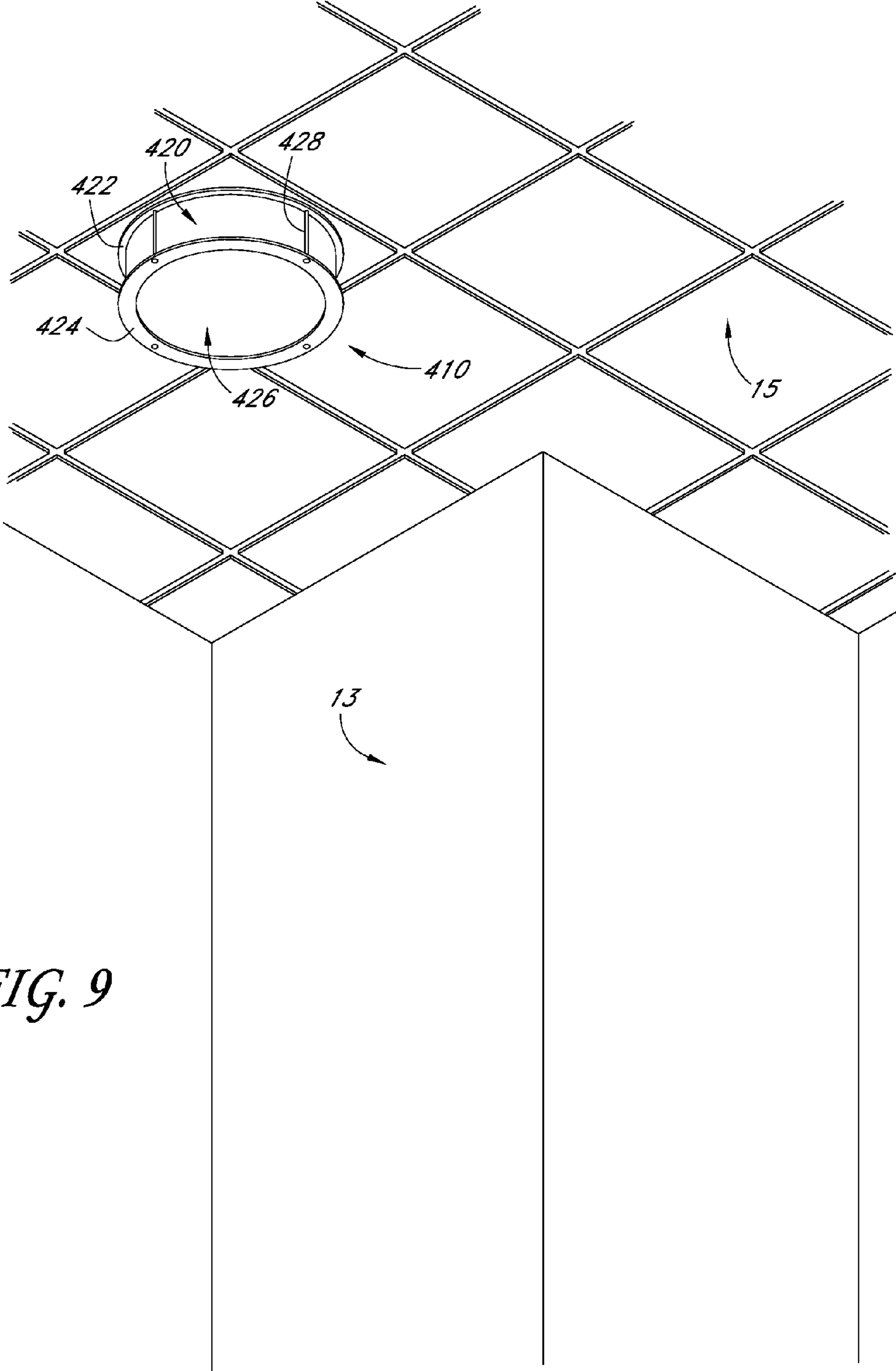

FIG. 9

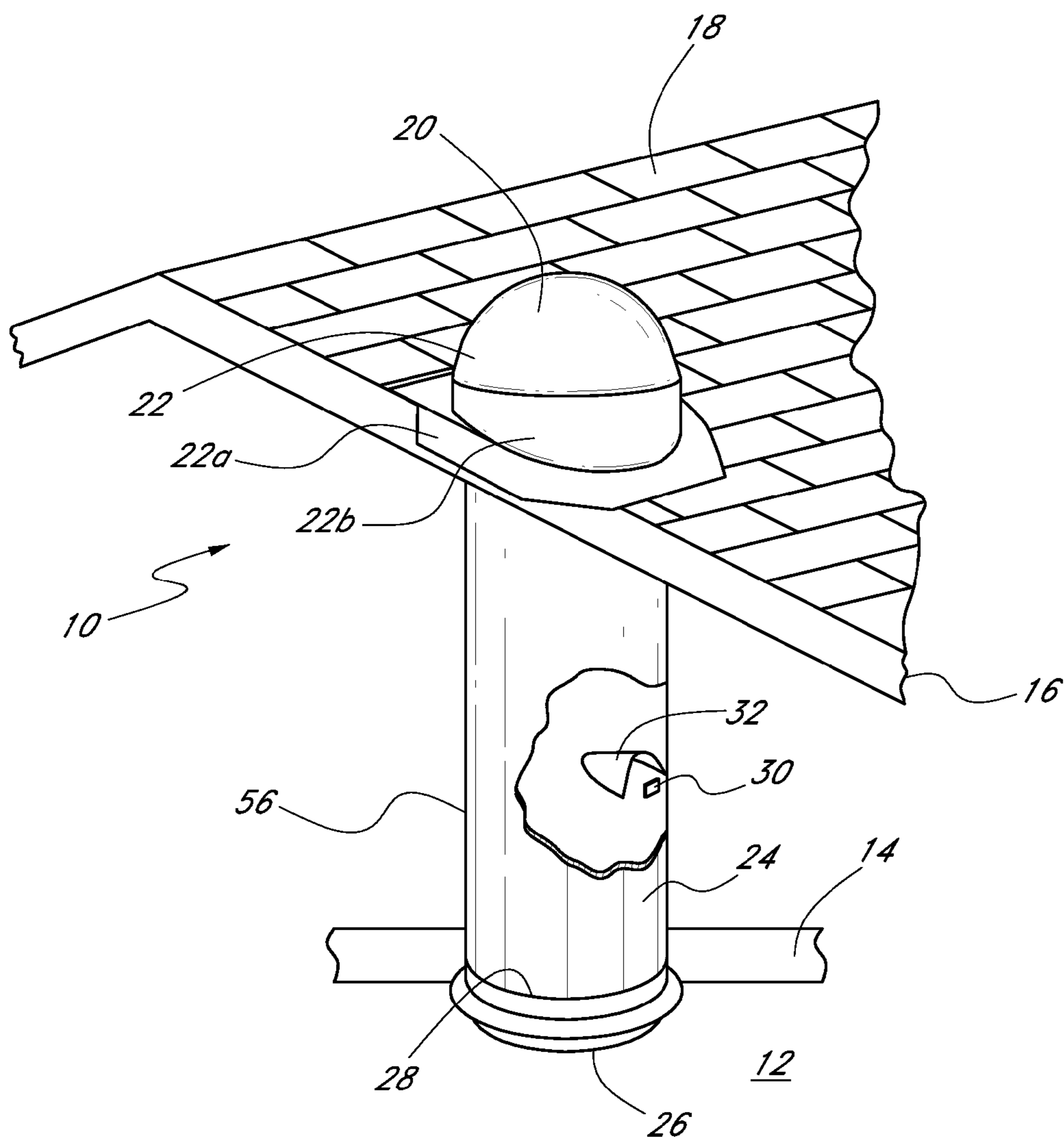

FIG. 10

1

DAYLIGHTING DEVICES WITH AUXILIARY LIGHTING SYSTEM AND LIGHT TURNING FEATURES

RELATED APPLICATIONS

This application is a continuation-in-part of U.S. patent application Ser. No. 12/545,016, filed Aug. 20, 2009, titled DAYLIGHTING DEVICES AND METHODS WITH AUXILIARY LIGHTING FIXTURES. This application is a continuation-in-part of U.S. patent application Ser. No. 12/636,650, filed Dec. 11, 2009, titled DIRECT AND INDIRECT LIGHT DIFFUSING DEVICES AND METHODS. The entire contents of each of the above-referenced applications are incorporated by reference herein and made a part of this specification.

BACKGROUND

1. Field

This disclosure relates generally to daylighting systems and methods and more particularly to light diffusing devices and methods.

2. Description of Related Art

Daylighting systems typically include windows, openings, and/or surfaces that provide natural light to the interior of a structure. Examples of daylighting systems include skylight and tubular daylighting device (TDD) installations. In a TDD installation, a transparent cover can be mounted on a roof of a building or in another suitable location. An internally reflective tube can connect the cover to a diffuser mounted in a room or area to be illuminated. The diffuser can be installed in a ceiling of the room or in another suitable location. Natural light entering the cover on the roof can propagate through the tube and reach the diffuser, which disperses the natural light throughout the interior of the structure. Certain currently known devices and methods for diffusing light suffer from various drawbacks.

SUMMARY

Example embodiments described herein have several features, no single one of which is indispensable or solely responsible for their desirable attributes. Without limiting the scope of the claims, some of the advantageous features will now be summarized.

Some embodiments provide a daylighting apparatus comprising an internally reflective tube configured to direct daylight from a first end of the tube to a second end of the tube opposite the first end. A diffuser can be positioned at the second end of the tube. The diffuser can comprise a first optical structure configured such that, when the daylighting apparatus is installed with the first end positioned outside a room and the second end positioned to provide light to the room, a reflected portion of the daylight is directed towards at least one upper region (e.g., a ceiling or upper wall surface) of the room and a transmitted portion of the daylight is directed towards at least one lower region (e.g., a floor surface) of the room.

The first optical structure can comprise a reflective surface shaped and positioned to change the direction of propagation of the reflected portion of the daylight. The reflective surface can comprise at least a first face configured to reflect collimated daylight at a first incident angle. The reflective surface can comprise at least a second face configured to reflect the

2

collimated daylight at a second incident angle different from the first incident angle. The reflective surface can comprise a plurality of additional faces.

The reflective surface can comprise at least a first curved face configured to reflect collimated daylight at a plurality of incident angles. The reflective surface can comprise a lower reflective face region, a middle reflective face region, and an upper reflective face region. Each of the lower reflective face region, the middle reflective face region, and the upper reflective face region can be a conical frustum. The first optical structure can comprise a reflective element with many different shapes, such as the general shape of a frustum of a hyperboloid.

The first optical structure can comprise at least one aperture shaped and positioned to permit at least some of the transmitted portion of the daylight to pass through the first optical structure. The first optical structure can comprise at least one reflective surface interrupted by a plurality of openings configured to permit at least some of the transmitted portion of the daylight to pass through the first optical structure.

The diffuser can comprise a second optical structure configured to receive light exiting the first optical structure. The second optical structure can be configured to spread the reflected portion of the daylight. The second optical structure can also be configured to spread the transmitted portion of the daylight.

Certain embodiments provide a method of providing light inside of a structure. The method can comprise the steps of positioning an internally reflective tube between a first location outside the structure and a second location in a room of the structure in a manner that permits daylight to be directed along the tube from the first location to the second location and positioning a diffuser at an end of the tube in the room such that the diffuser reflects a first substantial portion of the daylight exiting the tube towards at least one upper region (e.g., a ceiling and wall surface) of the room and permits a second substantial portion of the daylight exiting the tube to pass through the diffuser towards at least one lower region (e.g., a floor surface) of the room.

Positioning a diffuser can comprise positioning a first optical element configured to reflect at least some of the daylight and positioning a second optical element around the first optical element. The second optical element can be configured to spread the daylight exiting the tube. Positioning a diffuser at an end of the tube can comprise positioning an optical element such that it extends at least partially into the tube.

Some embodiments provide a method of manufacturing a daylighting device. The method can comprise the steps of disposing a reflective material on each side of a substrate to form at least one sheet having two reflective surfaces; cutting or otherwise forming the sheet to include a plurality of openings in the sheet; shaping the at least one sheet to form an optical element having at least one reflective face region with a generally circular cross-section and an aperture extending through the at least one reflective face region; and placing the optical element at one end of an internally reflective tube. The tube can be configured to receive daylight and to direct the daylight towards the optical element. Shaping the at least one sheet can comprise shaping at least a first sheet and a second sheet and joining the first sheet and the second sheet to form the optical element.

The method can comprise the step of placing a second optical element over the first optical element, the second optical element configured to spread light exiting the tube. The optical element can be configured such that, when the

3

daylighting apparatus is installed with the first end positioned outside a room and the second end positioned to provide light to the room, a reflected portion of the daylight is directed towards at least one ceiling or wall surface of the room and a transmitted portion of the daylight is directed towards at least one floor surface of the room.

BRIEF DESCRIPTION OF THE DRAWINGS

Various embodiments are depicted in the accompanying drawings for illustrative purposes, and should in no way be interpreted as limiting the scope of the inventions. In addition, various features of different disclosed embodiments can be combined to form additional embodiments, which are part of this disclosure. Any feature or structure can be removed or omitted. Throughout the drawings, reference numbers may be reused to indicate correspondence between reference elements.

FIG. 1 schematically illustrates an example of a TDD installation.

FIG. 2A is a cross-sectional detail view of an example TDD installation with an optical element having a generally continuously-curved reflective surface.

FIG. 2B is a cross-sectional detail view of an example TDD installation with an optical element having a reflective surface with multiple faces in a segmented shape.

FIG. 3 is a ray diagram illustrating a propagation of light through the example TDD installation illustrated in FIG. 2B.

FIG. 4 is another ray diagram illustrating a propagation of light through the example TDD installation illustrated in FIG. 2B.

FIG. 5 is a ray diagram illustrating a propagation of light through an example TDD installation with a perforated optical element.

FIG. 6 is a ray diagram illustrating a propagation of light through an example TDD installation with a first optical element and a second optical element.

FIG. 7 is a cross-sectional view showing certain dimensions and proportions of an example TDD installation with a diffuser.

FIG. 8 is a perspective view of an example diffuser and an example additional optical element.

FIG. 9 is a perspective view of an example TDD installation with a diffuser and an additional optical element.

FIG. 10 is a cutaway illustration of a TDD installation.

DETAILED DESCRIPTION OF PREFERRED EMBODIMENTS

Although certain preferred embodiments and examples are disclosed below, inventive subject matter extends beyond the specifically disclosed embodiments to other alternative embodiments and/or uses, and to modifications and equivalents thereof. Thus, the scope of the claims appended hereto is not limited by any of the particular embodiments described below. For example, in any method or process disclosed herein, the acts or operations of the method or process may be performed in any suitable sequence and are not necessarily limited to any particular disclosed sequence. Various operations may be described as multiple discrete operations in turn, in a manner that may be helpful in understanding certain embodiments; however, the order of description should not be construed to imply that these operations are order dependent. Additionally, the structures, systems, and/or devices described herein may be embodied as integrated components or as separate components. For purposes of comparing various embodiments, certain aspects and advantages of these

4

embodiments are described. Not necessarily all such aspects or advantages are achieved by any particular embodiment. Thus, for example, various embodiments may be carried out in a manner that achieves or optimizes one advantage or group of advantages as taught herein without necessarily achieving other aspects or advantages as may also be taught or suggested herein.

In some embodiments, a TDD installation transports sunlight from the roof of a building to the interior via a tube with a reflective surface on the tube interior. A TDD installation can sometimes also be referred to as a “tubular skylight.” A TDD installation can include a transparent cover installed on the roof of a building or in another suitable location. A tube with a reflective surface on the tube interior extends between the cover and a diffuser installed at the base of the tube. The transparent cover can be dome-shaped or can have another suitable shape and can be configured to capture sunlight. In certain embodiments, the cover keeps environmental moisture and other material from entering the tube. The diffuser spreads light from the tube into the room or area in which the diffuser is situated.

The cover can allow exterior light, such as daylight, to enter the system. In some embodiments, the cover includes a light collection system configured to enhance or increase the daylight entering the tube. In certain embodiments, a TDD installation includes a light mixing system. For example, the light mixing system can be positioned in the tube or integrated with the tube and can be configured to transfer light in the direction of the diffuser. The diffuser can be configured to distribute or disperse the light generally throughout a room or area inside the building. Various diffuser designs are possible. An auxiliary lighting system can be installed in a TDD to provide light from the tube to the targeted area when daylight is not available in sufficient quantity to provide a desired level of interior lighting.

The direction of light reflecting through the tube can be affected by various light propagation factors. Light propagation factors include the angle at which the light enters the TDD, which can sometimes be called the “entrance angle.” The entrance angle can be affected by, among other things, the solar elevation, optics in the transparent cover, and the angle of the cover with respect to the ground. Other light propagation factors include the slope of one or more portions of a tube sidewall and the specularly of the sidewall’s internal reflective surface. The large number of possible combinations of light propagation factors throughout a single day can result in light exiting the TDD at a wide and continuously varying range of angles.

FIG. 1 shows a cutaway view of an example of a TDD 10 installed in a building 16 for illuminating, with natural light, an interior room 12 of the building 16. The TDD 10 includes a transparent cover 20 mounted on a roof 18 of the building 16 that allows natural light to enter a tube 24. The cover 20 can be mounted to the roof 18 using a flashing. The flashing can include a flange 22a that is attached to the roof 18, and a curb 22b that rises upwardly from the flange 22a and is angled as appropriate for the cant of the roof 18 to engage and hold the cover 20 in a generally vertically upright orientation. Other orientations are also possible.

The tube 24 can be connected to the flashing 22 and can extend from the roof 18 through a ceiling 14 of the interior room 12. The tube 24 can direct light L_D that enters the tube 24 downwardly to a light diffuser 26, which disperses the light in the room 12. The interior surface 25 of the tube 24 can be reflective. In some embodiments, the tube 24 has at least a section with substantially parallel sidewalls (e.g., a generally cylindrical surface). Many other tube shapes and configura-

5

tions are possible. The tube **24** can be made of metal, fiber, plastic, a rigid material, an alloy, another appropriate material, or a combination of materials. For example, the body of the tube **24** can be constructed from type 1150 alloy aluminum. The shape, position, configuration, and materials of the tube **24** can be selected to increase or maximize the portion of daylight L_D or other types of light entering the tube **24** that propagates into the room **12**.

The tube **24** can terminate at or be functionally coupled to a light diffuser **26**. The light diffuser **26** can include one or more devices that spread out or scatter light in a suitable manner across a larger area than would result without the diffuser **26** or devices thereof. In some embodiments, the diffuser **26** permits most or substantially all visible light traveling down the tube **24** to propagate into the room **12**. The diffuser can include one or more lenses, ground glass, holographic diffusers, other diffusive materials, or a combination of materials. The diffuser **26** can be connected to the tube **24** using any suitable connection technique. For example, a seal ring **28** can be surroundingly engaged with the tube **24** and connected to the light diffuser **26** in order to hold the diffuser **26** onto the end of the tube **24**. In some embodiments, the diffuser **26** is located in the same general plane as the ceiling **14**, generally parallel to the plane of the ceiling, or near the plane of the ceiling **14**.

In certain embodiments, the diameter of the diffuser **26** is substantially equal to the diameter of the tube **24**, slightly greater than the diameter of the tube **24**, slightly less than the diameter of the tube **24**, or substantially greater than the diameter of the tube **24**. The diffuser **26** can distribute light incident on the diffuser toward a lower surface (e.g., the floor **11**) below the diffuser and, in some room configurations, toward an upper surface (e.g., at least one wall **13** or ceiling surface **15**) of the room **12**. The diffuser **26** can spread the light such that, for example, light from a diffuser area of at least about 1 square foot and/or less than or equal to about 4 square feet can be distributed over a floor and/or wall area of at least about 60 square feet and/or less than or equal to about 200 square feet in a typical room configuration.

Diffusers that employ principally direct diffusion, such as downward directing diffusers, distribute light in certain ways that can be undesirable. Some direct diffusers distribute light such that the intensity of light on the floor **11** when measured on a horizontal plane is highest directly under the diffuser **26** and decreases with distance away from the location directly under the diffuser **26**. In some instances, the distribution of light on the floor is characterized by a cosine effect. For example, the intensity of the light can be directly related to the cosine of the incident angle of the light to the floor and inversely related to the distance between the diffuser **26** and the floor. Accordingly, non-uniform floor light levels are typically observed when certain types of diffusers are used in a TDD **10**. Further, certain types of direct diffusers are characterized by intense light exiting the diffuser **26** from ceiling levels less than 15 feet at angles of 45 to 60 degrees (measured from vertical). Intense light at those angles can create visibility problems in an area, including glare and computer screen washout. The contrast of the bright diffuser area and the dark non-illuminated ceiling can also increase the perceived glare and reduce the view of the ceiling area. These are some common undesirable characteristics related to downward directing diffusers.

Diffusers that employ principally indirect diffusion typically distribute light principally to the ceiling and/or walls of an area. Indirect diffusers can also distribute light in ways that are undesirable. For example, indirect diffusers typically distribute a smaller portion of light to the floor **11** or working

6

areas than direct diffusers. Thus, there may be a substantially dark or dimly-lit area on the floor **11** directly under the TDD **10**.

In some embodiments, a diffuser **26** provides substantial amounts of both direct diffusion and indirect diffusion. In certain embodiments, a diffuser **26** redirects a portion of the light L_D that exits the tube **26** at the ceiling level onto a surrounding upper region (e.g., a ceiling surface **15**) and distributes the remainder to a lower region (e.g., the floor **11** and walls **13**). Such a diffuser **26** can illuminate the floor **11** more uniformly. Light L_D that is projected onto the painted ceiling surface **15** and walls **13** will reflect off of these surfaces **13**, **15** in a diffuse, widespread pattern that will mix the light considerably before reaching the floor level **11**. Allowing a portion or fraction of the light L_D to pass directly to the floor **11** through a diffuser **26** or light spreading device can mitigate or eliminate the occurrence of a dark area under the TDD **10**.

In some embodiments, a diffuser **26** reduces the light intensity in a region greater than or equal to about 45° and/or less than or equal to about 60° azimuthally away from the axis of the tube **24** by distributing more light L_D upward to the ceiling surface **15**, thereby eliminating or reducing the incidence of glare and display washout. Further, light that passes through the hollow interior of the diffuser **26** can be directed or controlled such that it has an exit angle of less than about 45° from vertical. When at least the areas of the ceiling surface **15** near the TDD **10** or other areas generally in the upper portion of the room **12** are illuminated, the contrast ratio between the diffuser **26** and the surrounding ceiling surface **15** can be reduced, and a brighter overall room appearance can be created.

In the embodiments illustrated in FIGS. 2A-2B, an optical element **110** is suspended below the level of the ceiling **14** in order to direct light onto the ceiling surface **15**. The distance z that the optical element **110** extends below the ceiling **14** can be selected such that the optical element **110** directs adequate light towards the ceiling surface **15** while not substantially intruding into the available space of the room **12**. Factors that may affect the selection of the distance z can include ceiling height, other room dimensions, aesthetics, other functional or architectural factors, or a combination of factors. For example, a shorter distance z may be selected when the TDD **10** is installed in a room **12** with low ceiling height. In some embodiments, the distance z is less than the height of the diffuser **26**.

As shown in FIG. 2A, the diffuser **26** can include a curved optical element **110** placed directly below and partially inside the base of the tube **24**. In the example embodiment illustrated in FIG. 2A, the shape of the optical element **110** can generally conform to a right circular, outwardly concave frusto-hyperbolic section. Many other variations in the shape of the optical element **110** are possible. In some embodiments, the optical element **110** is shaped to reflect light incident over the area of the element **110** at a plurality of incident angles such that light turned by the optical element **110** is dispersed over a relatively large angular range (for example, at least about 180° or at least about 200°). In certain embodiments, the light incident on the optical element **110** is substantially collimated while the light exiting the optical element **110** is substantially distributed throughout the room **12** in which the TDD **10** is installed. In some embodiments, the distribution of light exiting the optical element **110** includes a substantial portion of light dispersed across each of the upper and lower regions (e.g., the ceiling surface **15**, walls **13**, and floor **11**) of the room **12**.

The optical element **110** can be constructed from a material system including, for example, metal, plastic, paper, glass, ceramic, a coating, a film, another suitable material, or a combination of materials. In some embodiments, the optical element **110** includes an aluminum substrate with a reflective coating on each face. The optical element **110** illustrated in FIG. **2A** has a reflective, concave outer face **116** that extends circumferentially about an axis. The outer face **116** faces away from the axis, while a reflective, convex inner face **117** opposite the outer face **116** faces towards the axis, toward the hollow interior of the optical element **110**. In certain embodiments, the central axis of the optical element **110** is substantially collinear with a central axis of the tube **24**.

The surfaces of the outer face **116** and the inner face **117** can be made reflective by any suitable technique, including, for example, electroplating, anodizing, coating, or covering the surfaces **116**, **117** with a reflective film. Reflective films can be highly reflective in at least the visible spectrum and include metallic films, metalized plastic films, multi-layer reflective films, or any other structure that substantially reflects light in the visible spectrum. The material from which the optical element **110** is constructed may also be inherently reflective. In some embodiments, at least a portion of the surfaces of the outer face **116** and the inner face **117** are generally specular.

A top plane **112** of the optical element **110** is generally open so that light traveling down the tube **24** can pass into the hollow interior of the element **110**. A bottom plane **114** of the element **110** is also generally open such that light propagating through the interior of the element **110** can exit the element **110** and enter the room **12** below in the general direction of the floor **11**. The aperture of the top plane **112** and the aperture of the bottom plane **114** can be substantially circular or any other suitable shape. In some embodiments, one or more of the apertures are the same shape as the shape of a cross-section of the tube **24**. In certain embodiments, the diameter of the bottom plane **114** aperture is substantially equal to the diameter of the tube **24**, slightly greater than the diameter of the tube **24**, slightly less than the diameter of the tube **24**, or substantially greater than the diameter of the tube **24**. The diameter of the top plane **112** aperture can be smaller than the diameter of the bottom plane **114** aperture, less than or equal to about half the diameter of the bottom plane **114** aperture, less than or equal to about 75% of the diameter of the bottom plane **114** aperture, or another suitable diameter. In some embodiments, the diameter of the top plane **112** aperture is selected to achieve a desired ratio of direct diffusion to indirect diffusion. For example, if a higher ratio of direct diffusion to indirect diffusion is desired, then the diameter of the aperture of the top plane **112** can be increased.

In some embodiments, the typical incident angle of substantially collimated light propagating down the tube **24** and incident on the optical element **110** depends on whether the light is incident on one of the reflective faces **116**, **117** at a position near the top plane **112** or whether the light is incident at a position near the bottom plane **114** of the optical element **110**. In the example illustrated embodiment, the shape of the faces **116**, **117** permits the angle of incidence for collimated incoming light to be larger at positions closer to the top plane **112** and comparatively smaller at positions closer to the bottom plane **114** of the optical element **110**. While FIG. **2A** shows an optical element **110** with reflective faces **116**, **117** having a particular curvature, it is understood that faces **116**, **117** having other curvature or shapes can be used. For example, in some embodiments, the vertical cross-section of the faces **116**, **117** (for example, the cross-section shown in FIG. **2A**) can have a generally elliptical shape, a generally

hyperbolic shape, a generally parabolic shape, a generally negative intrinsic curvature, a generally positive intrinsic curvature, another geometry, or a combination of differently-shaped regions. The shape of the faces **116**, **117** can be selected such that a substantial amount of light is directed towards the floor **11**, wall **13**, and ceiling surfaces **15** of the room **12** when the optical element **110** is positioned below the tube **24** in a TDD **10** installation.

The example diffuser **26** illustrated in FIG. **2B** includes an optical element **210** having a shape generally conforming to a plurality (e.g., three) contiguous right circular frusto-conical sections. Many other variations in the shape of the optical element **210** are possible. The illustrated optical element **210** has a hollow interior and can be placed below and partially inside the tube **24**. In some embodiments, the optical element **210** has a plurality of faces **216a-c**, **217a-c** oriented at various angles to reflect light incident over the area of the element **210** at a plurality of incident angles such that light turned by the optical element **210** is dispersed over a relatively large angular range (for example, at least about 180° or at least about 200°). In certain embodiments, the light incident on the optical element **210** is substantially collimated while the light exiting the optical element **210** is substantially distributed throughout the room **12** in which the TDD **10** is installed. In some embodiments, the distribution of light exiting the optical element **210** includes a substantial portion of light dispersed across each of the upper and lower regions (e.g., the ceiling surface **15**, walls **13**, and floor **11**) of the room **12**.

The optical element **210** can be constructed from a variety of materials, including the materials discussed with respect to the optical element **110** described previously. The optical element **210** illustrated in FIG. **2B** has a plurality of reflective outer faces **216a-c** that extend generally circumferentially about an axis. The outer faces **216a-c** face away from the axis, while a plurality of reflective inner faces **217a-c** generally opposite the outer faces **216a-c** face toward the hollow interior of the optical element **210**. In certain embodiments, the central axis of the optical element **210** is substantially collinear with a central axis of the tube **24**.

A top plane **212** of the optical element **210** is generally open so that light traveling down the tube **24** can pass into the hollow interior of the element **210**. A bottom plane **214** of the element **210** is also open such that light propagating through the interior of the element **210** can exit the element **210** and enter the room **12** below in the general direction of the floor **11**. The shapes and sizes of the top plane **212** aperture and the bottom plane **214** aperture can be selected in at least the same ways as the shapes and sizes of the apertures of the optical element **110** described previously.

In some embodiments, the incident angle of substantially collimated light propagating down the tube **24** and incident on the optical element **210** is different when the light is incident on a surface near the top plane **212** than when the light is incident on a surface near the bottom plane **214** of the optical element **210**. In the example illustrated embodiment, the arrangement of the plurality of faces **216a-c**, **217a-c** permits the angle of incidence for collimated incoming light to be larger at the faces **216a**, **217a** closer to the top plane **212** (“top faces”) of the optical element **210** and comparatively smaller at the faces **216c**, **217c** closer to the bottom plane **214** (“bottom faces”) of the optical element **210**. The arrangement of the faces **216b**, **217b** between the top faces **216a**, **217a** and the bottom faces **216c**, **217c** (“middle faces”) can permit the incident angle of the collimated light at the middle faces **216b**, **217b** to be between the incident angle at the top faces **216a**, **217a** and the incident angle at the bottom faces **216c**, **217c** in magnitude. While the illustrated embodiment has

three regions of reflective faces, it is understood that any number of reflective face regions can be employed, including, for example, one region, two regions, four regions, more than four regions, two or more regions, between two and four regions, and so forth.

The number and configuration of exterior faces **116a-c** and interior faces **117a-c** can be selected such that a substantial amount of light is directed towards the floor **11**, wall **13**, and ceiling surfaces **15** of the room **12** when the optical element **210** is positioned below the tube **24** in a TDD **10** installation, or such that light is distributed generally uniformly around both upper and lower regions of a room at the same time. For example, in some embodiments light can be distributed by the diffuser **26** generally continuously across a region extending from a plane generally parallel with the base **214** of the optical element **210** to a plane generally perpendicular to the to the diffuser **26** and generally parallel to the axis of the tube **24**. In certain embodiments, light can be distributed by the diffuser **26** generally continuously through an angle sweeping from an upper region of the room **12** generally adjacent to or near the TDD **10** to a lower region of the room **12** generally below the TDD **10**. For example, the diffuser **26** can direct portions of incoming daylight upwards, to the left, to the right, and/or downwards.

The optical element **210** can include transition regions **218a-b** disposed between reflective faces having differing geometry. For example, a first transition region **218a** can be disposed between the top faces **216a**, **217a** and the middle faces **216b**, **217b**, and a second transition region **218b** can be disposed between the middle faces **216b**, **217b** and the bottom faces **216c**, **217c**. In some embodiments, the number of transition regions **218a-b** is equal to one less than the number of reflective face regions having differing geometry. For example, the example embodiment illustrated in FIG. 2B has three frustoconical face regions having different slant angles and two transition regions **218a-b**. The transition regions **218a-b** can include creases, rounded corners, or other transitional elements between reflective face regions. In some embodiments, the transition regions **218a-b** form a sharp transition between reflective face regions. Alternatively, the transition regions **218a-b** can form a more gradual transition between reflective face regions.

The optical element **210** can control and distribute light exiting the tube **24** according to various optical element design properties and their associated principles. In the example embodiment illustrated in FIG. 3, the reflective surfaces **216a-c**, **217a-c** of the optical element **210** are designed to accommodate a specific range of angles of light to maintain a constant, a nearly constant, or a substantially evened illumination on the ceiling surfaces **15** and walls (not shown) of the room **12**. Light reflects down the tube **24** at the same elevation angle from horizontal at which the light entered the tube **24**. Therefore, for most inhabited locations on the planet, in many embodiments, the elevation angle from horizontal of light entering the tube **24** will range from about 20 to 70 degrees. The elevation angle depends on the sun angle, which varies throughout the course of a day and also throughout the course of a year.

The propagation of light through the tube **24** and the interaction of light with the optical element **210** vary with the elevation angle of the light. For example, in some embodiments, light A entering at lower sun angles will reflect once off a sloped surface **216b** of the optical element **210**, as shown in FIG. 3. In certain such embodiments, light B entering the tube **24** at higher sun angles will reflect multiple times off surfaces **216a**, **216c** of the optical element **210**. Accordingly, both the low-angle light A and the high-angle light B are

directed towards the ceiling surface **15** at exit angles that are considerably closer than the elevation angles of the light when it entered the tube **24**. By reflecting light differently depending on the elevation angle of the light, the optical element **210** can provide similar exit angles and illumination on the ceiling surface **15** and walls of the room **12** for high elevation angle light and low elevation angle light.

The top plane **212** of the optical element **210** can be open, substantially open, or at least partially open to allow light C to transmit down to the area below the tube **24** (for example, towards the floor of the room **12**). In the example embodiment illustrated in FIG. 4, light C passes through the top plane **212** and reflects off an interior face **217a** of the optical element **210**. The interior face **217a** turns the light C such that the exit angle of the light C from the TDD **10** is closer to vertical than the entrance angle of the light C. In some embodiments, the optical element **210** increases the elevation angle from horizontal of at least a portion of the light propagating through the interior of the optical element **210** such that the at least a portion of the light exits the TDD **10** at a more vertical angle, as illustrated. The degree to which the light C is turned can depend on the orientation and position of the portion of the interior face **217** on which the light C is incident.

In certain embodiments, the optical element **210** is designed to ensure that light passing through the optical element **210** will exit the bottom plane **214** of the optical element **210** at an exit angle of less than about 45 degrees from vertical or at a nearly vertical orientation in order to reduce or prevent the light C from exiting the TDD **10** at a 45 to 60 degree angle from vertical. In this manner, the optical element **210** can reduce or eliminate the glare and visibility issues that light exiting a fixture at those angles can cause.

In the example embodiment illustrated in FIGS. 5 and 8, an optical element **310** is shown that can resemble the optical elements **110**, **210** described previously in many ways, but differs in manners such as those discussed hereafter. The optical element **310** has exterior faces **316a-c** and interior faces **317a-c** that are at least partially reflective and at least partially transmissive. In some embodiments, the optical element **310** is constructed from a material **332** that is perforated, cut, molded, or otherwise constructed such that the material is interrupted by a plurality of openings **334** that extend through the material. The openings **334** can be sized and positioned in order to allow a substantial amount of light D2 to transmit downward and a substantial amount of light D1 to be reflected towards the ceiling surfaces **15** or walls of the room **12**. Incident light D is turned when it is incident on the reflective material **332** but transmits through the openings **334**. In some embodiments, the openings **334** are generally evenly distributed over the surface of the optical element **310**. Alternatively, the openings **334** can be distributed according to a pattern that is configured to produce any desired effect.

In some embodiments, the openings **334**, **434** are not true physical openings, but merely optical openings formed of translucent or transparent material surrounded by or adjacent to opaque or reflective material. Other structures or configurations can also be used to permit a portion of the light to be directed generally perpendicularly to the diffuser **26** and a portion of the light to be directed generally in the direction of the periphery of the diffuser **26**.

In certain embodiments, the openings **334** are configured such that the total area encompassed by the openings is about 50% of the surface area of the optical element **310**. Alternatively, the openings can be configured such that the openings **334** cover less than or equal to about 60% of the surface, more than or equal to about 40% of the surface, or another portion that can be selected to give the optical element **310** any

11

desired optical characteristics. By adjusting the size and arrangements of openings 334 in the optical element 310, a TDD manufacturer can tailor the reflection and transmission characteristics of the optical element 310 to account for the relative amount of illumination needed on the ceiling surface 15, walls, and/or floor of the room 12. In certain embodiments, the illumination on the ceiling surface 15, walls, and/or floor of the room 12 emanating from a TDD installation can be adjusted without increasing or decreasing the size of the tube.

One or more optical elements in addition to the optical elements 210, 310 described above can be used to further control the distribution of light as it exits the TDD 10. In the example embodiment illustrated in FIGS. 6, 8 and 9, a second optical element 410 is disposed between the optical element 210 and the room 12. The second optical element 410 is a light diffusing structure configured to interact with light E, F reflected by and/or light G passing through the optical element 210. In the embodiment illustrated in FIG. 6, light E propagating along a first path reflects off the interior surface 25 of the tube 24 and is incident on the optical element 210 at a middle exterior face 216b. The middle exterior face 216b reflects and turns the light E toward the ceiling surface 15. The light E propagates to the second optical element 410, which spreads the light. Light E1 exiting the second optical element 410 is spread in a diffused pattern generally toward the ceiling surfaces 15 and walls 13 of the room 12. Light F propagating along a second path is incident on the optical element at an upper exterior face 216a. The upper exterior face 216a reflects and turns the light F toward a lower exterior face 216c of the optical element 210. The lower exterior face 216c reflects and turns the light F generally toward the ceiling surface 15. The light F propagates to the second optical element 410, which spreads the light. Light F1 exiting the second optical element 410 is spread in a diffused pattern generally toward the ceiling surfaces 15 and walls 13 of the room 12. Light G propagating along a third path reflects off the interior surface 25 of the tube 24 and passes through the optical element 210. The light G propagates to the second optical element 410, which spreads the light. Light G1 exiting the second optical element 410 is spread in a diffused pattern generally toward the floor 11 of the room 12.

Many variations in the shape, position, and construction of the second optical element 410 are possible. The second optical element 410 can include a first diffusing surface 420 extending from the ceiling 14 to the base of the optical element 210. A second diffusing surface 426 can refract light exiting the base 214 of the optical element 210. The diffusing surfaces 420, 426 can be made from any suitable material such as, for example, transparent plastic, translucent plastic, glass, one or more lenses, ground glass, holographic diffusers, another diffusing material, or a combination of materials.

In some embodiments, at least one of the diffusing surfaces 420, 426 comprises a substantially continuous diffusing material 432, a diffusing material 432 interspersed with openings 434, another material, or a combination of materials. The second optical element 410 can reduce the contrast between the TDD 10 and the ceiling surfaces 15 and/or walls 13 surrounding the TDD 10 by further diffusing light E1, F1, G1 exiting the TDD 10. In certain embodiments, the first optical element 210 turns at least a portion of incident light E, F using a shaped reflective surface while the second optical element 410 spreads incident light E, F, G using refraction or photon diffusion. In some embodiments, the diffusing surfaces 420, 426 are held in place or supported by supporting structures. The supporting structures can be constructed from any suit-

12

able material and can include rings 424, 426, rods 428, other structural elements, or a combination of elements.

Example dimensions and proportions of the TDD will now be discussed with reference to the embodiment shown in FIG. 7. In some embodiments, the design of the TDD 10 is compact. For example, the width or diameter W2 (width dimension) of the base 214 of the optical element 210 may be approximately equal to the width dimension W1 of the tube 24. In some embodiments, the width dimension W2 of the base 214 is less than or equal to the sum of the width dimension W1 of the tube 24 and a relative short distance (e.g., about one inch). In an example embodiment, the diameter W2 of the base 214 is 21.25" when the diameter W1 of the tube 24 is 21". Other suitable tube 24 and optical element 210 dimensions can be selected as appropriate to provide desired lighting and diffusion characteristics to the room 12.

In certain embodiments, the optical element 210 extends a short distance L2 from the ceiling 14 into the room 12. For example, the distance L2 between the ceiling 14 and the base 214 of the optical element 210 can be at least about six inches and/or less than or equal to about twelve inches, less than or equal to about twelve inches, or less than or equal to about nine inches. In some embodiments, the optical element 210 extends at least partially into the tube 24. For example, if the height L1 of the optical element 210 is 8.85" and the distance L2 between the base 214 of the optical element 210 and the ceiling 14 is 6.5", then the optical element 210 will extend 2.35" into the tube. By positioning the optical element 210 at least partially into the tube 24, the distance between the base 214 of the optical element 210 and the ceiling 14 can be decreased.

FIG. 10 shows a cutaway view of an example of a tubular skylight 10 installed in a building for illuminating, with natural light, an interior room 12 of a building 16. The tubular skylight 10 includes a transparent cover 20 mounted on a roof 18 of the building 16 that allows natural light to enter a tube 24. The cover 20 can be mounted to the roof 18 using a flashing 22. The flashing 22 can include a flange 22a that is attached to the roof 18, and a curb 22b that rises upwardly from the flange 22a and is angled as appropriate for the cant of the roof 18 to engage and hold the cover 20 in a generally vertically upright orientation.

The tube 24 can be connected to the flashing 22 and can extend from the roof 18 through a ceiling 14 of the interior room 12. The tube 24 can direct light that enters the tube 24 downwardly to a light diffuser 26, which disperses the light in the room 12. The inside of the tube 24 can be reflective. The tube 24 can be made of metal, fiber, plastic, a rigid material, an alloy, another appropriate material, or a combination of materials. For example, the body the tube 24 can be constructed from type 1150 alloy aluminum.

The tube 24 can terminate at a light diffuser 26. The light diffuser 26 can include one or more devices that spread out or scatter light in a suitable manner. In some embodiments, the diffuser 26 absorbs relatively little or no visible light and transmits most or all incident visible light, at least at certain angles of incidence. The diffuser can include one or more lenses, ground glass, holographic diffusers, or any other suitable diffusers. The diffuser 26 can be connected to the tube 24 using any suitable connection technique. For example, a seal ring 28 can be surroundingly engaged with the tube 24 and connected to the light diffuser 26 to hold the diffuser 26 onto the end of the tube 24.

An auxiliary light source 30 can be disposed inside the tube 24. In certain embodiments, the light source 30 can be attached to an interior or exterior side wall of the tube 24 in a generally vertical orientation, as shown in FIG. 10, for

13

example. In some embodiments, the light source **30** can be disposed in another suitable position, including behind or in front of the side wall of the tube **24**. For example, the light source **30** can be connected to a projection extending from the side wall into the interior of the tube **24**. As another example, the light source **30** can be positioned in a recess that extends from the side wall outward from the interior of the tube **24**.

A light control surface **32** can be disposed adjacent to the light source **30** and can at least partially surround the light source **30**. The light control surface **32** can also be attached to the side wall of the tube **24** on the side of the light source **30** closest to the cover **20**. The light control surface **32** is configured to direct light emanating upwardly from the light source **30** in a downward direction towards the diffuser **26**. Without the light control surface **32**, a portion of the directed light would propagate up the tube **24** in the direction of the cover **20** and exit the tube **24** into the exterior environment. Thus, the light control surface **32** can increase luminous intensity at the diffuser **26** while the luminosity of the auxiliary light source **30** is held constant. The light control surface **32** can also increase the collimation of light incident on the diffuser **26**. In certain instances, the optical efficiency of the diffuser **26** is increased when incident light is more nearly collimated.

At least some of the embodiments disclosed herein may provide one or more advantages over existing daylighting systems. For example, certain embodiments effectively allow a TDD to distribute light exiting the TDD onto the upper and lower regions of a room (e.g., the ceiling, walls, and/or floor). As another example, some embodiments provide techniques for allowing substantially light transmission directly beneath a TDD and to the sides of the TDD. As another example, certain embodiments provide an indirect diffuser that also allows a portion of incident light to transmit directly through the diffuser. As another example, some embodiments provide an indirect diffuser that provides substantial illumination directly below the diffuser and has reduced contrast between the base of the diffuser and an illuminated ceiling.

Discussion of the various embodiments disclosed herein has generally followed the embodiments illustrated in the figures. However, it is contemplated that the particular features, structures, or characteristics of any embodiments discussed herein may be combined in any suitable manner in one or more separate embodiments not expressly illustrated or described. For example, it is understood that a diffuser can include multiple optical elements, reflective surfaces, and/or diffusing surfaces. In many cases, structures that are described or illustrated as unitary or contiguous can be separated while still performing the function(s) of the unitary structure. In many instances, structures that are described or illustrated as separate can be joined or combined while still performing the function(s) of the separated structures. It is further understood that the diffusers disclosed herein may be used in at least some daylighting systems and/or other lighting installations besides TDDs.

It should be appreciated that in the above description of embodiments, various features are sometimes grouped together in a single embodiment, figure, or description thereof for the purpose of streamlining the disclosure and aiding in the understanding of one or more of the various inventive aspects. This method of disclosure, however, is not to be interpreted as reflecting an intention that any claim require more features than are expressly recited in that claim. Moreover, any components, features, or steps illustrated and/or described in a particular embodiment herein can be applied to or used with any other embodiment(s). Thus, it is intended that the scope of the inventions herein disclosed should not be

14

limited by the particular embodiments described above, but should be determined only by a fair reading of the claims that follow.

What is claimed is:

1. A daylighting apparatus comprising:
 - a transparent cover configured to receive daylight;
 - a tube having a sidewall with a reflective interior surface, wherein the tube is configured to receive at least a portion of the daylight received by the transparent cover and direct the at least a portion of the daylight towards a room of a building, wherein the tube is disposed at least partially above a ceiling of the room;
 - an auxiliary lighting system configured to provide artificial light to the tube; and
 - an optical element having one or more reflective interior faces configured to simultaneously receive at least a portion of the daylight and at least a portion of the artificial light, and to turn light received by the one or more reflective interior faces such that an exit angle of the light is closer to vertical than an entrance angle of the light, wherein a width of a bottom of the optical element is greater than a width of a base of the tube.
2. The daylighting apparatus of claim 1, wherein the exit angle is less than about 45 degrees from vertical.
3. The daylighting apparatus of claim 1, wherein the exit angle is substantially vertical.
4. The daylighting apparatus of claim 1, wherein the optical element is configured to prevent light from exiting the daylighting device at a 45 to 60 degree angle from vertical.
5. The daylighting apparatus of claim 1, wherein the optical element is configured to reduce glare associated with light exiting the daylighting device.
6. The daylighting apparatus of claim 1, wherein the one or more interior faces comprises a first face and a second face positioned farther away from a top of the optical element than the first face.
7. The daylighting apparatus of claim 6, wherein an angle between the first face and vertical is less than an angle between the second face and vertical.
8. The daylighting apparatus of claim 7, wherein the one or more interior faces comprises a third face positioned farther away from the top of the light aligning apparatus than the second face, and wherein an angle between the second face and vertical is less than an angle between the third face and vertical.
9. The daylighting apparatus of claim 1, further comprising a light-diffusing apparatus.
10. The daylighting apparatus of claim 9, wherein the light-diffusing apparatus is disposed at least partially below the ceiling.
11. The daylighting apparatus of claim 9, wherein the optical element is disposed at least partially within the light-diffusing apparatus.
12. The daylighting apparatus of claim 1, wherein the optical element is disposed at least partially below the ceiling.
13. The daylighting apparatus of claim 1, wherein a width of a bottom of the optical element is substantially equal to a width of a base of the tube.
14. The daylighting apparatus of claim 1, wherein a width of the light-diffusing apparatus is substantially equal to a width of a bottom of the optical element.
15. The daylighting apparatus of claim 1, wherein the optical element is disposed at least partially within the tube.
16. A daylighting apparatus comprising:
 - a transparent cover configured to receive daylight;
 - a tube having a sidewall with a reflective interior surface, wherein the tube is configured to receive at least a por-

15

tion of the daylight received by the transparent cover and direct the at least a portion of the daylight towards a room of a building, wherein the tube is disposed at least partially above a ceiling of the room;

an auxiliary lighting system configured to provide artificial light to the tube; and

an optical element having one or more reflective interior faces configured to receive light and turn the light such that an exit angle of the light is closer to vertical than an entrance angle of the light;

wherein at least a portion of the optical element extends below a base of the tube.

17. A method of manufacturing a daylighting apparatus, the method comprising:

providing a tube having a sidewall with a reflective interior surface;

providing a transparent cover configured to connect to the tube;

providing an optical element having one or more reflective interior faces and configured to connect to the tube;

providing an auxiliary lighting system for the daylighting apparatus;

wherein the one or more reflective interior faces are configured to receive light and turn the light such that an exit angle of the light is closer to vertical than an entrance angle of the light;

wherein at least a portion of the optical element is configured to extend below a base of the tube.

18. A daylighting apparatus comprising:

a transparent cover configured to receive daylight;

a tube having a sidewall with a reflective interior surface, wherein the tube is configured to receive at least a portion of the daylight received by the transparent cover and direct the at least a portion of the daylight towards a room of a building, wherein the tube is disposed at least partially above a ceiling of the room;

16

an auxiliary lighting system configured to provide artificial light to the tube; and

an optical element having one or more reflective interior faces configured to simultaneously receive at least a portion of the daylight and at least a portion of the artificial light, and to turn light received by the one or more reflective interior faces such that an exit angle of the light is closer to vertical than an entrance angle of the light, wherein a width of the light-diffusing apparatus is substantially equal to a width of a bottom of the optical element.

19. A daylighting apparatus comprising:

a transparent cover configured to receive daylight;

a tube having a sidewall with a reflective interior surface, wherein the tube is configured to receive at least a portion of the daylight received by the transparent cover and direct the at least a portion of the daylight towards a room of a building, wherein the tube is disposed at least partially above a ceiling of the room;

an auxiliary lighting system configured to provide artificial light to the tube; and

an optical element having one or more reflective interior faces configured to simultaneously receive at least a portion of the daylight and at least a portion of the artificial light, and to turn light received by the one or more reflective interior faces such that an exit angle of the light is closer to vertical than an entrance angle of the light;

wherein the one or more interior faces comprises a first face and a second face positioned farther away from a top of the optical element than the first face;

wherein an angle between the first face and vertical is less than an angle between the second face and vertical.

* * * * *